



INTAKE SYSTEMS FOR VEHICLES LISTED ARE 50 STATE LEGAL. SEE KNFILTERS.COM FOR CARB STATUS ON EACH PART FOR A SPECIFIC VEHICLE.

INSTALLATION INSTRUCTIONS

77-9020KP
TOYOTA
2000-02 Tundra
2001-04 Sequoia
V8-4.7L

NOTE: This kit was not designed to fit vehicles with a body lift.

TOOLS NEEDED:

- Ratchet
- Extension
- 10mm Socket
- 12mm Socket
- Phillips Screwdriver
- Flat Blade Screwdriver
- 2.5mm Allen
- 9/64" Allen
- 10mm Wrench

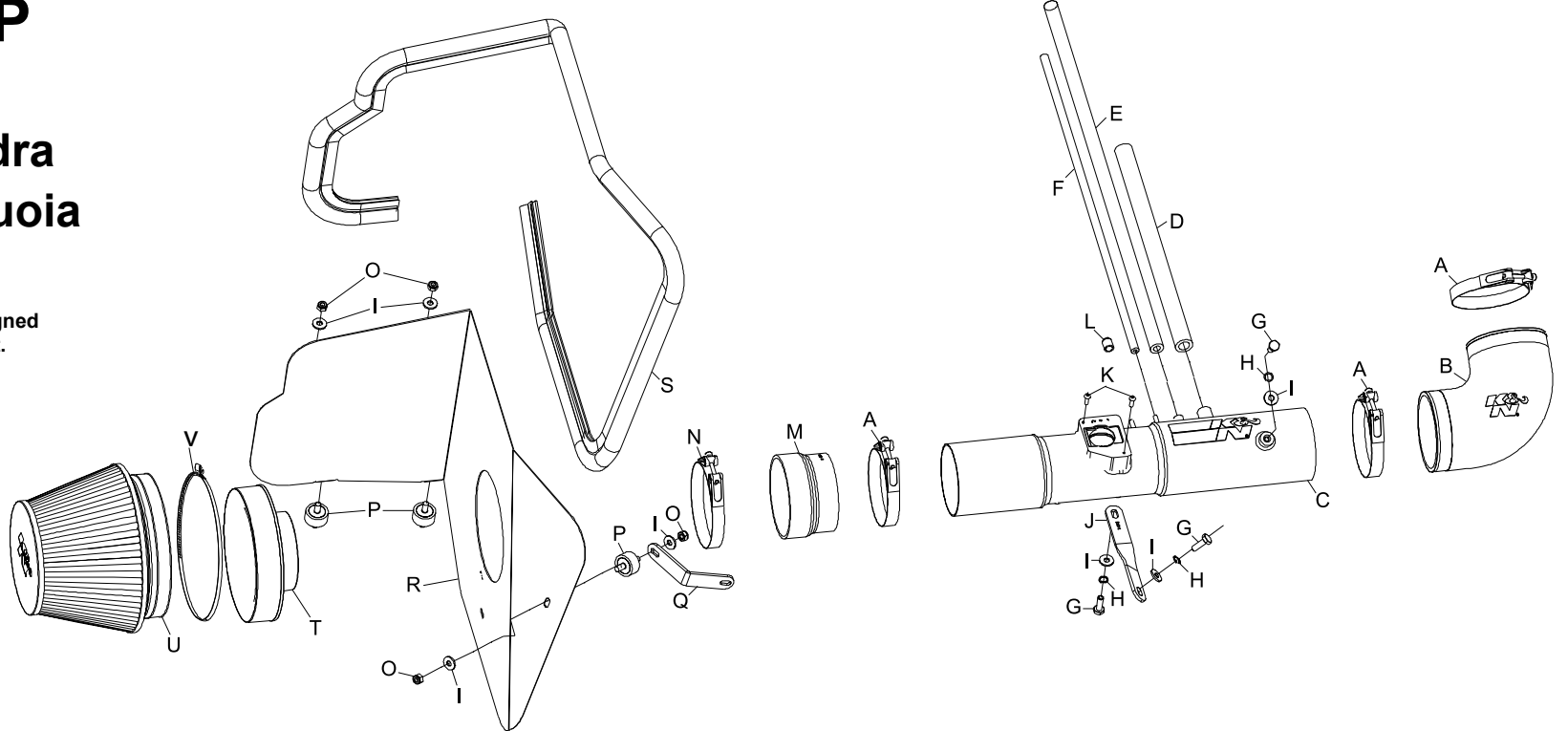

PARTS LIST:

Description	Qty.	Part #	Description	Qty.	Part #	Description	Qty.	Part #
A Hose clamp; #52	3	08610	I Washer; 1/4" id x 5/8" od, flat	7	08275	Q Bracket; angled	1	070581
B hose 3-1/4" id 90deg	1	084095	J Bracket; twist	1	010113	R heat shield	1	07433
C intake tube	1	27359	K Bolt; m4-.7 x 12, B/H/A	2	07726	S edge trim 61"	1	102492
D hose; 1/2" id x 12" l, silicone	1	087031	L Caplug; 5/16" id x 1/2" L, black	1	08131	T filter adapter #380	1	21512-1
E hose; 5/16" id x 21" l, silicone	1	08409	M hose; 3.25" id to 3.50" id x 2.25" l,	1	084091	U air filter	1	RC-2960
F hose; 4mm id x 18" l, silicone	1	08153	N Hose clamp; #56	1	08620	V hose clamp #104	1	08697
G Bolt; m6-1.00 x 16mm hex	3	07703	O Nut; 6mm nylock	4	07553			
H Washer; 1/4" split lock	3	08198	P Stud; m6-1.00m/m, rubber mntd	3	07027			

If you need any assistance please call 1-800-858-3333 to speak with a representative in our Customer Service Center before returning the product.

NOTE: FAILURE TO FOLLOW INSTALLATION INSTRUCTIONS AND NOT USING THE PROVIDED HARDWARE MAY DAMAGE THE INTAKE TUBE, THROTTLE BODY AND ENGINE.

TO START:

1. Turn off the ignition and disconnect the negative battery cable.
NOTE: Disconnecting the negative battery cable erases pre-programmed electronic memories. Write down all memory settings before disconnecting the negative battery cable. Some radios will require an anti-theft code to be entered after the battery is reconnected. The anti-theft code is typically supplied with your owner's manual. In the event your vehicles' anti-theft code cannot be recovered, contact an authorized dealership to obtain your vehicles anti-theft code.



2. Disconnect the mass-air connection



3. Loosen and remove the acorn nuts that secure the throttle body cover, then remove the cover.



4. Loosen and remove the bolt that secures the AC line to the stock intake tube.



5. Loosen the hose clamp at the throttle body.



6. Loosen the three bolts that secure the air box assembly.

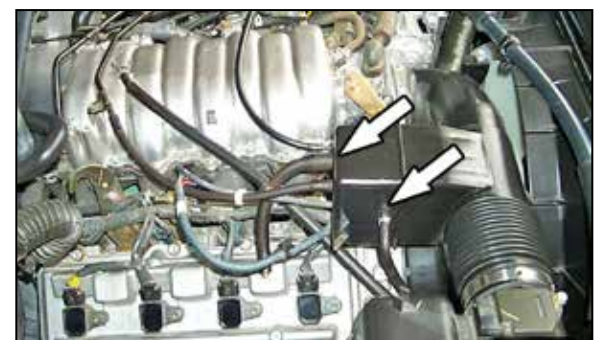

7. Disconnect the four rubber hoses from the engine as shown by the arrows.
NOTE: Some '03 models may come equipped with only three vacuum lines.



8. Remove the complete air induction system.
NOTE: K&N Engineering, Inc., recommends that customers do not discard factory air intake.



9. Loosen and remove the two screws that secure the mass-air sensor, then remove the mass-air sensor.



10. Install the mass-air sensor into the K&N® intake tube, and secure with the provided screws as shown.



11. Apply the edge trim to the K&N® heat shield as shown above, trim if needed.



12. Install the rubber mounted stud onto the heat shield as shown with the provided hardware.



13. Install the heat shield mounting bracket onto the rubber mounted stud installed in step #12 with the provided hardware.



14. Install the two remaining rubber mounted studs to the original air box mounting holes.



15. Install the heat shield onto the rubber mounted studs as shown above.



16. Secure the upper bracket to the fan shroud with the original bolt.



17. Install the provided silicone hose (084095) onto the throttle body with the provided hose clamps.

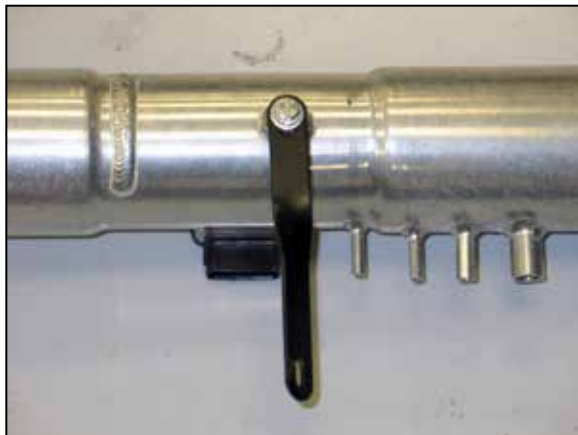

18. Install the tube mounting bracket onto the K&N® intake tube with the provided hardware as shown.

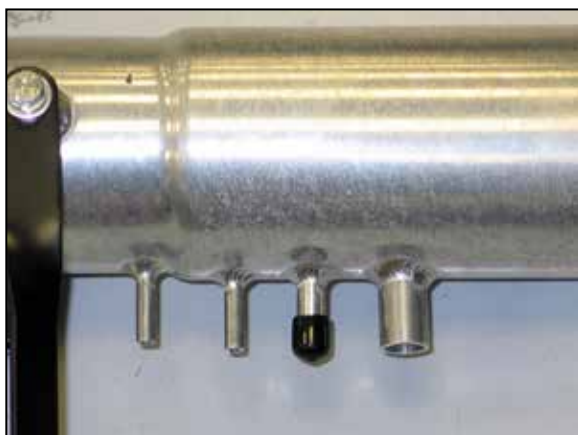

19. On vehicles that are not equipped with the 4th vacuum line, install the provided plug onto the vent tube as shown.



20. Install the K&N® intake tube into the silicone hose at the throttle body and then align the tube mounting bracket with the threaded boss on the engine valve cover. Secure the tube with the provided hardware and tighten the hose clamp.



21. Reconnect the A/C line to the K&N® intake tube using the original bolt removed in step #4.

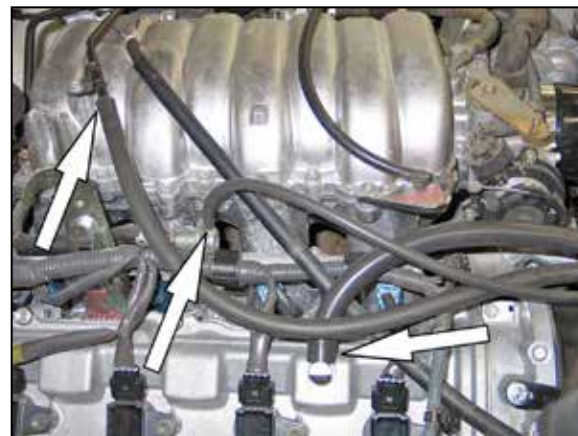

22. Replace the crank case vent line, EVAP vent line, and fuel pressure vent line with vent lines supplied.



23. Install the one factory P/S vent line, crank case vent line, EVAP vent line, and fuel pressure vent line onto the K&N® intake as shown.

NOTE: Some vehicles may not come with the EVAP vent line.



24. Install the filter adapter into the air filter as shown and secure with the provided hose clamp.



25. Install the silicone hose (084091) onto the filter adapter and secure with the provided hose clamp as shown.



26. Install the air filter assembly onto the K&N® intake tube as shown.



27. Reinstall the throttle body cover and secure with the original nuts.



28. Reconnect the mass air sensor electrical connection.



29. Reconnect the vehicle's negative battery cable. Double check to make sure everything is tight and properly positioned before starting the vehicle.

30. The C.A.R.B. exemption sticker, (attached), must be visible under the hood so that an emissions inspector can see it when the vehicle is required to be tested for emissions. California requires testing every two years, other states may vary.

31. It will be necessary for all K&N® high flow intake systems to be checked periodically for realignment, clearance and tightening of all connections. Failure to follow the above instructions or proper maintenance may void warranty.

ROAD TESTING:

1. Start the engine with the transmission in neutral or park, and the parking brake engaged. Listen for air leaks or odd noises. For air leaks secure hoses and connections. For odd noises, find cause and repair before proceeding. This kit will function identically to the factory system except for being louder and much more responsive.

2. Test drive the vehicle. Listen for odd noises or rattles and fix as necessary.

3. If road test is fine, you can now enjoy the added power and performance from your kit.

4. K&N Engineering, Inc., requires cleaning the intake system's air filter element every 100,000 miles. When used in dusty or off-road environments, our filters will require cleaning more often. We recommend that you visually inspect your filter once every 25,000 miles to determine if the screen is still visible. When the screen is no longer visible some place on the filter element, it is time to clean it. To clean and re-oil, purchase our filter Recharger® service kit, part number 99-5050 or 99-5000 and follow the easy instructions.

INTAKE SYSTEMS FOR VEHICLES LISTED ARE 50 STATE LEGAL. SEE KNFILTERS.COM FOR CARB STATUS ON EACH PART FOR A SPECIFIC VEHICLE.